

ORTEC[®]

Alpha/Beta Counting Multi-Detector Systems (MDS)



α / β

Ultra High Performance Alpha/Beta Counting Systems
for Maximum Laboratory Productivity

AMETEK[®]
ADVANCED MEASUREMENT TECHNOLOGY

Alpha/Beta Counting Multi-Detector Systems

The Multi-Detector System (MDS) is a multi-detector, low-background system for low-level background alpha and beta counting. The MDS is a premium system available for applications requiring high sample throughput and high sensitivity.

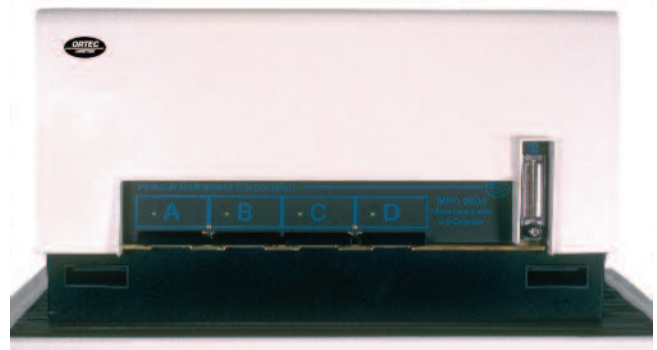

Key Features

Third Generation Design with

- Independent Sample Drawers
- Independent Sample Detectors
- Zero Adjacent Detector Crosstalk
- Reliable Communications Protocol
- Full Frontal Easy Service Access
- Complete Modularity
- Parallel Gas Distribution
- GasPRO™ Flow Sensing
- Dead-time Corrected Count Timer

Field Expandable

- Supports from 4 up to 48 detectors
- Modular design for enhanced flexibility

The Throughput Solution

The multi-detector system was designed to provide high throughput for low background beta counting. The MDS is ideal for applications looking to improve sample throughput when high sensitivity requirements dictate long counting times. One such application is the gross alpha/beta analysis of water and environmental samples. In this category ORTEC's MDS has no equal.

Anytime parallel processing of samples is called for a multi-detector system is the answer. The multi-detector alpha/beta counting system's main goal is to provide multiple sample channels allowing for parallel counting, in a compact footprint, at an economical price, without sacrificing performance.

Performance Matters

The MDS has the lowest backgrounds in the industry. This is achieved for both alpha and beta by carefully selecting and using only low background materials. To enhance the beta background the counting chambers are surrounded with four inches of virgin lead. Next a large area guard detector is placed on top of the sample detectors such that it intercepts and rejects cosmic events that would otherwise register as betas.

The MDS uses linear (non-switching) low voltage power supplies to eliminate one source of electrical interference. It also uses spectroscopy grade amplifiers to shape and filter the detector signals. The detector is biased with a regulated high voltage

Lowest Backgrounds in the Industry

- Four Inch 4π Virgin Lead Shield
- Cosmic Guard Detectors
- Selected Low Background Materials
- Linear Low Voltage Power Supplies

Vista 2000 Comprehensive Software

- MS Access™ Database (Non-relational)
- Intuitive Database Navigation
- Sample and Source Logs
- QC Control Charts
- Linked Count and Calibration Methods
- Count Presets or Count to MDA
- Standard and Custom Reports



Alpha/Beta Counting Multi-Detector Systems

supply. The high voltage and the detector signals are routed through shielded cables. The electronics are shielded with RFI guards and metal enclosures. This helps eliminate multiple sources of potential background noise.

Attention to detail is reflected in the MPC-9604's outstanding counting efficiency performance. Details such as detector uniformity, low density windows, precise counting geometry, low noise amplifiers, low crosstalk, dead time correction, etc., all combine to raise the bar for efficiency performance.

System Expansion from 4 to 48 Detectors

The core of the MDS system is the MPC-9604, a self-contained four detector unit. An MDS system consists of one or more MPC-9604 units, a control PC, a printer, and software. Each MPC-9604 unit contains four completely independent sample detectors, a guard detector, lead shielding, and all support electronics for that unit. The design of the MPC-9604 and control software allows for easy system expansion. Since each MPC-9604 is self-contained, the only connections required are the interface cable, the P-10 gas supply, and the AC power.

Up to twelve MPC-9604 units can be connected to a single PC, for a maximum of 48 independent channels. You can start with a minimum system, and add additional capacity as your budget or work load expands.

Communications between the PC and the MPC-9604 units is fast, reliable and inexpensive utilizing IEEE RS-485 standards and an exclusive PICNET II protocol. The control software automatically identifies new additions and configures itself to match.

True Detector Independence

The advanced design of the MDS allows each detector to be individually controlled and as they are mechanically independent. Routine use of a counting channel, including sample loading and unloading, calibrating, counting, and routine maintenance, is done without affecting other detectors in the system.

If a window replacement is required on one detector, it can be done while other detectors continue to count. Post maintenance performance checks can be conducted on only the affected detector. This optimizes system availability and uptime for increased sample counting.

Parallel Gas Flow with GasPRO™

Regulated P-10 gas enters each MPC-9604 through a quick disconnect, flows through a particle filter, a critical flow orifice that sets and limits the flow rate, a flow meter and then into a manifold that provides parallel (as opposed to serial) gas distribution to the detectors. Parallel flow is essential for independence and stability. The exclusive GasPRO™, featuring a low flow gas sensor, monitors the system for any P-10 gas fault and pauses counting until the fault is corrected.

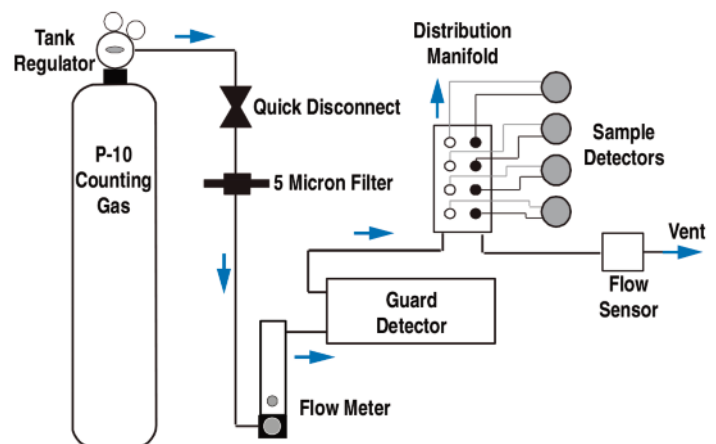
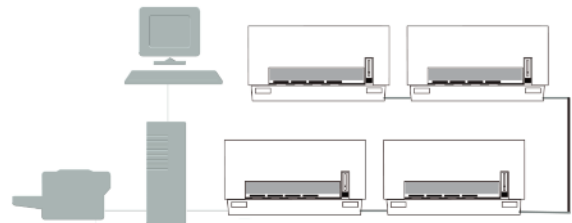

Alpha/Beta Counting Multi-Detector Systems

Compact Design

The MDS conserves lab space and since rear access is not required, no space is wasted. Each MPC-9604 unit is designed to fit on a standard lab bench, or you may consider the optional mobile cart (ACC-02), or an optional multiple unit rack (MDS-RACK). Multiple units can be more appropriately spaced since the PICNET II interface works at distances of several meters with high noise immunity using inexpensive network cables.



Easy to Maintain

The third-generation MDS is designed for easy maintenance. Older generations were intended to be serviced by factory trained engineers only. The MPC-9604's front access and modularity – from the sample detector through to the electronics – minimizes down time and spare parts inventory costs.

Detectors and detector windows are fully accessible from the system front without the need to lift any lead bricks. Detector windows are affordable and can be changed in less than 10 minutes, without interrupting any other detector in the system! Electronics are modular and accessible from the front of the system – no rear access required – no wasted space.

The MDS is designed to minimize down time and to maximize counting effectiveness.

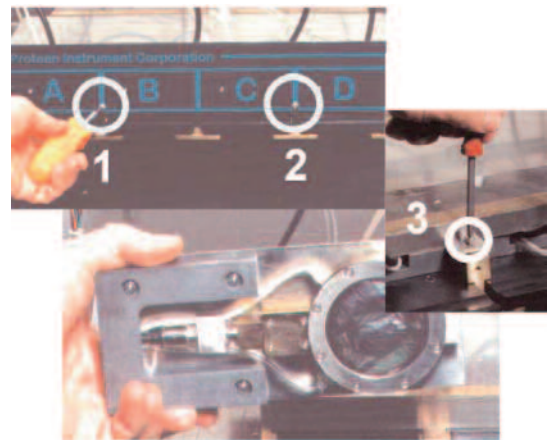

VISTA 2000 Control Software

The MDS is controlled through the comprehensive Vista 2000 software. Vista 2000 is a MS Windows based application used exclusively with ORTEC's extensive line of alpha/beta counting instrumentation. This software not only supports the MDS system but will also simultaneously support single detector windowless units and units with automatic sample changers.

All data for the system is contained in a Microsoft Access™ database with a simple, reliable, intelligent design. Within the database, all sample counting data is contained in a single data table. The combination of an industry standard format, and a simple data structure mean analysis and reporting is easy. You spend less time learning how to program report generators and database applications, and more time counting samples.

Samples and their specific parameters are logged into the database as batches and linked to a predefined count method. The count method is linked to predefined calibration methods that include detector specific calibration records. Samples are assigned to detectors from the sample log. The specified count method includes reporting units, maximum permissible concentration levels, alarm levels and messages, MDA techniques, default parameters, count presets.

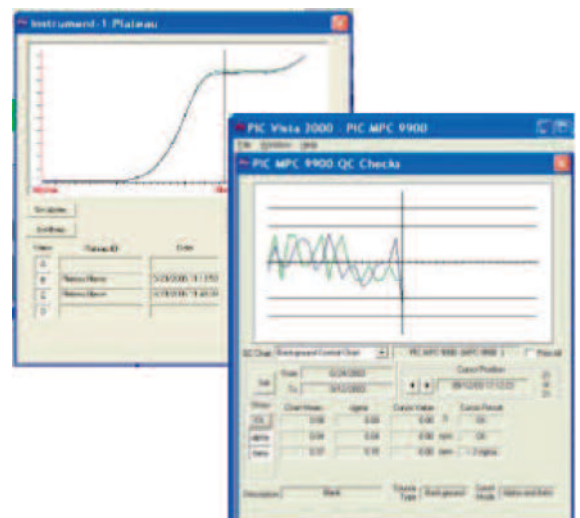
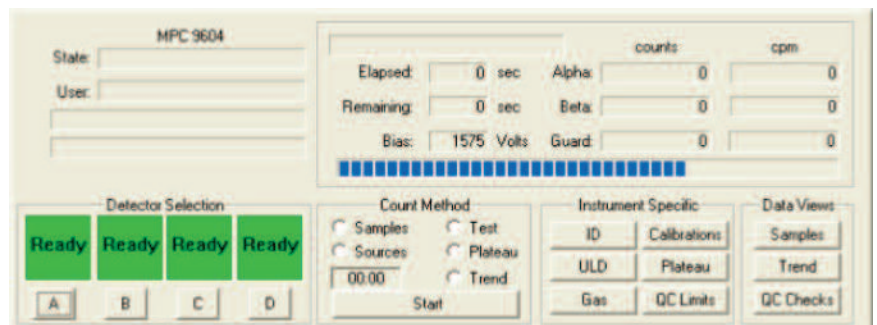

Alpha/Beta Counting Multi-Detector Systems

Count to MDA

Vista 2000 ensures that each detector has its own unique set of calibration records. If your methods require mass attenuation correction, each detector has its own independent correction coefficients. Vista 2000 and the MDS supports true count to MDA. In this case the counting time is automatically optimized for each sample with MDA values calculated individually for each detector based upon sample specific and detector specific calibration parameters using MDA equations selected from a set of the most widely used methods.

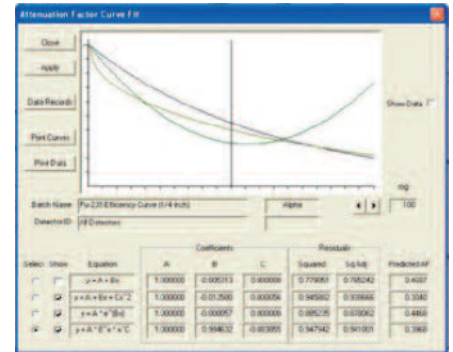

Diverse Calibrations

Differing sample analysis procedures require different counting methods, different calibration methods, different reporting methods, and different reporting units. Vista 2000 adapts to virtually every situation.

Whether your procedure uses single point constant mass efficiency calibrations, single point linked to a control chart, infinite thickness, variable mass with attenuation curves, common attenuation curves, or detector specific attenuation curves – Vista 2000 will adapt.

Vista 2000 doesn't tell you how to do your job. . . it provides the tools that allow you to do your job.

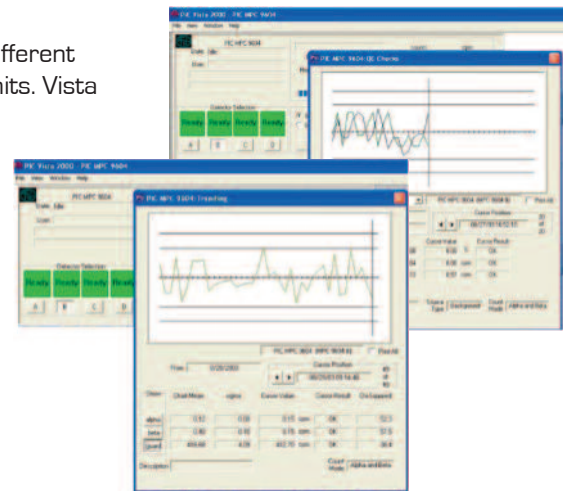

Easy to Use QC Functions

Vista 2000's flexible QC features are simple to set up and simple to use. Permanent data storage for Control Charts is provided in the MS Access™ database. Control Chart results may be automatically linked to calibration records.

Temporary testing and troubleshooting use trending functions that are similar to the Control Charts but not linked to the database to prevent clutter.

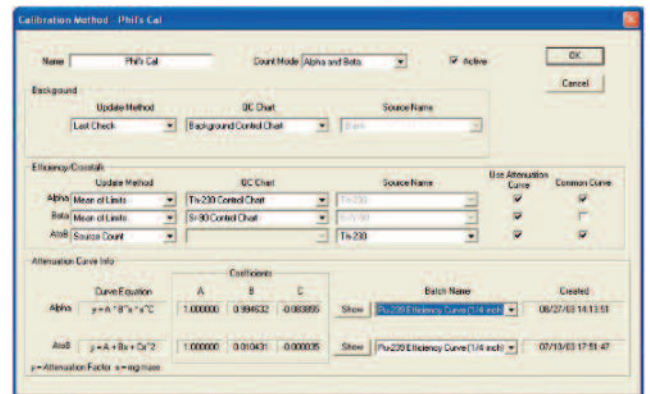

Library of Reports

Vista 2000 contains a set of standard reports written as XML files and designed to satisfy a majority of user applications.

- Detailed Reports
- Short Reports
- Wipes Reports
- Air Filter Reports

Custom reports can be developed and linked into Vista 2000 for seamless operation.

Custom and standard reports use Vista 2000's database navigator to extract batches of samples easily and intuitively.

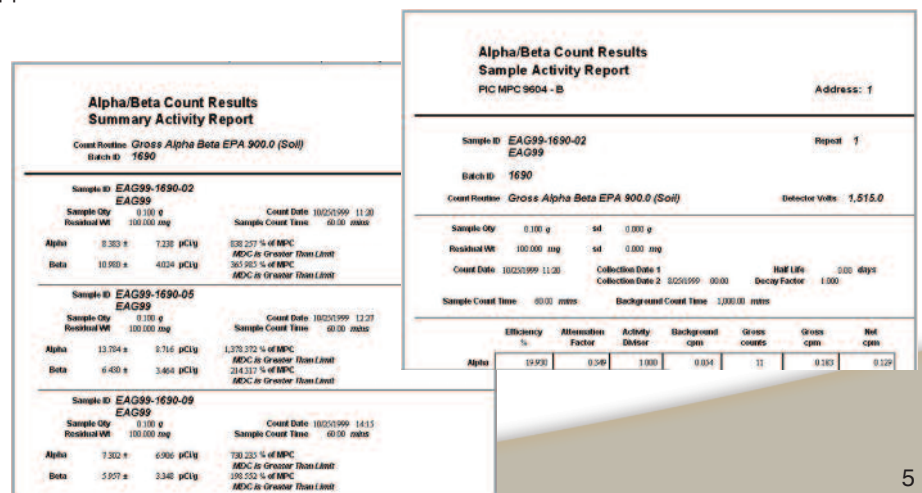

Alpha/Beta Counting Multi-Detector Systems

MDS Ordering Information

MDS systems are designated as -4, -8, -12, or -16, depending upon the total number of detectors. All MDS-XX systems will include one MPC-9604 unit per four detectors; gas line fittings and tubing, and two-stage gas tank regulators† (one per 8 detectors). Systems supplied to the U.S. domestic markets include a factory supplied PC including a Microsoft Windows operating system, Vista2000 control software, a laser printer, and installation. Export systems include a locally supplied PC and printer with installation provided by the nearest authorized representative. Vista 2000 requires a computer running Microsoft Windows 2000 or Windows XP as a minimum. The computer must have a native RS-232-C interface (converted USB ports will not work).

†Tank regulators use a US standard tank thread (CGA-350 .825"-14NGO-LH-EXT) and may require adapters not supplied by ORTEC.

MPC-9604 COUNTING PERFORMANCE

Each MPC-9604 contains four independent 2.25 inch diameter pancake style gas flow proportional sample detectors and a large area gas flow proportional cosmic guard detector. Each sample detector has a field replaceable (low cost) aluminized window with a nominal density of 100 µg/cm², 1 sample carrier with inserts for 1/8 inch, 1/4 inch, and 5/16 inch planchets per detector (planchets are not included). Each of the four channels of a MPC-9604 exhibits the following performance specifications.

		Alpha	Beta
Background	Typical	0.03 – 0.07 cpm	0.4 – 0.7 cpm
	Warranted	≤ 0.1 cpm	≤ 0.9 cpm
[Background values are dependent on environment and altitude. Warranted values are as measured at factory under controlled conditions.]			

		Alpha		Beta	
Efficiency	Typical	Po ²¹⁰	40%	Sr ⁹⁰ /Y ⁹⁰	55%
		Am ²⁴¹	40%	Cs ¹³⁷	40%
		Th ²³⁰	40%	Tc ⁹⁹	35%
[Efficiencies are typical values; energy and geometry dependent; as measured at factory under optimized conditions with factory specified sources; and, measured using P-10 counting gas.]					

		Alpha	Beta
Plateau	Slope	< 1.5%/100V	< 2.5%/100V
	Length	> 1000 volts	> 200 volts
[Plateau measurements use point sources at optimum geometry using P-10 counting gas. Alpha plateaus use Po ²¹⁰ : beta plateau use Sr ⁹⁰ /Y ⁹⁰]			

		Alpha to Beta	Beta to Alpha
Crosstalk	Instrument induced	< 0.1%	< 0.1%
	Naturally occurring	Source Dependent	Source Dependent

Alpha/Beta Counting Multi-Detector Systems

Detector Uniformity	> 95% over active area
Dead Time Correction	tested to 300,000 counts per minute with < 1.5% dead time loss for each detector channel simultaneously and independently
Count Modes	alpha only or simultaneous alpha + beta

MPC-9604 Physical

Gas-PRO™	Failsafe P-10 monitoring system senses breaches in flow
Gas Flow	Nominally set to 60 cc/min with a critical flow orifice. Each unit includes a rotameter style flow meter and a parallel feed gas distribution manifold for the counting gas. Nominal inlet pressure 10 psi (15 psi recommended maximum). (Refer to Applications Note AN-0807)
Shield	4" (10 cm) thick selected virgin lead
Size	32" W x 16" D x 16" H (81.3 cm W x 41 cm D x 41 cm H)
Weight	Installed 1200 lbs (545.5 kg) Shipping 1400 lbs (637 kg)
AC Power	117 V ac, < 1.7 A, 50/60 Hz; 230 V ac, < 0.9 A, 50/60 Hz
Environment	10 - 40° C; 20-90%, humidity, non-condensing

Options

MPC-9604	Self-contained four-detector unit to add counting capacity to an existing MDS system
MDS-RACK	Heavy duty rack assembly to hold two MPC-9604 units
ACC-02	Wheeled cart holding one MPC-9604 unit.

Alpha/Beta Counting Multi-Detector Systems

Specifications subject to change
092614

ORTEC[®]

www.ortec-online.com

Tel. (865) 482-4411 • Fax (865) 483-0396 • ortec.info@ametek.com
801 South Illinois Ave., Oak Ridge, TN 37830 U.S.A.
For International Office Locations, Visit Our Website

AMETEK[®]
ADVANCED MEASUREMENT TECHNOLOGY