

G3250-3850-320

Wide Range Segmented/Tomographic Gamma Scanner

Introduction

The ANTECH G3250-3850-320 Wide Range Segmented/Tomographic Gamma Scanner (WR-SGS/TGS) builds on the segmented gamma scanning technique to measure the radionuclide content of waste drums. The technique is applicable to the measurement of activity from extremely low levels to extremely high levels and across a large range of densities. It is capable of measuring waste in a variety of matrices and chemical forms and is particularly applicable when the chemical form and the relationship between the nuclide and matrix are unknown. In TGS mode the instrument uses transmission corrected, single photon emission computerised axial tomography to determine the spatial distribution and quantity of radionuclides in a drum or can. Combining WR-SGS and TGS technology makes the WR-SGS/TGS the most versatile waste measuring instrument available today.

As in the standard Segmented Gamma Scanner (SGS), the drum or sample is rotated about its vertical axis as horizontal segments are scanned. This allows for any inconsistencies in the matrix density whilst building a vertical profile of gamma-ray transmission and nuclide concentration. In TGS mode the drum is rotated through 2.5 revolutions while it is moved horizontally through one half drum radius.

The ANTECH G3250-3850-320 is the first SGS/TGS system to utilise both the storage of the transmission source within a tungsten shielded safe and a fully automated variable collimator aperture. The SGS mode variable aperture collimator greatly increases the range of activity that can be assayed on one measurement system without the need for any manual alteration. Laser alignment during assembly and PLC motor control ensures optimum alignment of the transmission source and the detector once the source leaves the safe. When the transmission source is stored in the safe, there is typically a leakage of less than 5 $\mu\text{Sv/hr}$ near the surface of the safe. In the safe storage position the detector does not detect any gamma-rays from the transmission source.

The ANTECH implementation of the WR-SGS/TGS technique in the Model G3250-3850-320 complies with the Standard Test Method for Non-destructive Assay by Segmented Passive Gamma-ray Scanning, ASTM number C1133-03.



Features

- Both WR-SGS and TGS operation
- Automated variable collimator aperture
- Safe storage of the transmission source when not in use (typically ^{152}Eu)
- Adjustable detector position for optimal measurement
- Conveyor based drum loading/unloading
- Optional built-in Geiger-Müller dose rate sensor
- Waste drum barcode recognition
- One or two pass measurement, emission and/or transmission
- Remote operation
- Windows based menu driven software for ease of use
- Helical drum scanning (WR-SGS)

Benefits

- Ability to detect both very low and very high activity gamma radiation in one measurement instrument
- Ability to measure relatively homogenous drums with WR-SGS method and highly heterogeneous drums with TGS method
- Typical measurement time of 30 minutes (WR-SGS) although increased accuracy and precision can be achieved by extending the measurement time and 60 minutes (TGS)
- Non-destructive assay of up to 320 litre overpack drums, including 200 litre drums
- Provides tomographic maps of absorbers and sources in heterogeneous matrices



Built-in Geiger-Müller dose rate sensor and waste drum barcode recognition

Specification

Dimensions (H x W x D)	2500 mm x 2900 x 1000 mm* (98.43 in x 114.17 in x 39.37 in*) *1700 mm (66.23 in) long conveyor illustrated in photo
Drum size	200 litre with 320 litre overpack
Variable collimator range	1 mm - 70 mm
Germanium Coax Detector efficiency	40% + typical (other detector efficiencies as an option)
Transmission source	¹⁵² Eu (typical)
Detectable activity range	Up to 10 ¹² Bq per drum
Density range	Up to 2000 kg/m ³
Analysis software	Windows operating platform, GammaScan user interface
Digital MCA	ORTEC DSPEC 50 or ANTECH DPA Model G3081 <500 VA including PC
Network connection	Ethernet

	Calculated MDA for 360s emission 120s transmission 3 layers (Bq)	ANTECH Calculated MDA for 0.3g/cc drum (kBq)
⁶⁰ Co	1.80E+02	0.54
⁵⁸ Co	7.30E+02	2.19
¹³⁴ Cs	7.50E+02	2.25
¹³⁷ Ca	9.50E+02	2.85
¹¹⁰ Ag	7.50E+02	2.25
⁵⁴ Mn	8.30E+02	2.49
⁵¹ Cr	7.00E+03	21
¹²⁴ Sb	6.70E+02	2.01
¹²³ Te	9.10E+02	2.73
¹⁵² Eu	2.20E+03	6.6
²³⁵ U	1.40E+03	4.2
²³⁹ Pu	1.50E+07	4.50E+04
²³⁸ U	1.30E+05	390

ANTECH WR-SGS MDA data is based on background measurements made at customer site (low background room in power plant). A density 0.3 sawdust drum was measured (3 segments, 0.5 hr total measurement time) with no sources. Helical scanning was employed with 360 s emission and 120 s transmission per segment. The Currie Limit formulation (1 sigma) was used to calculate the MDA.

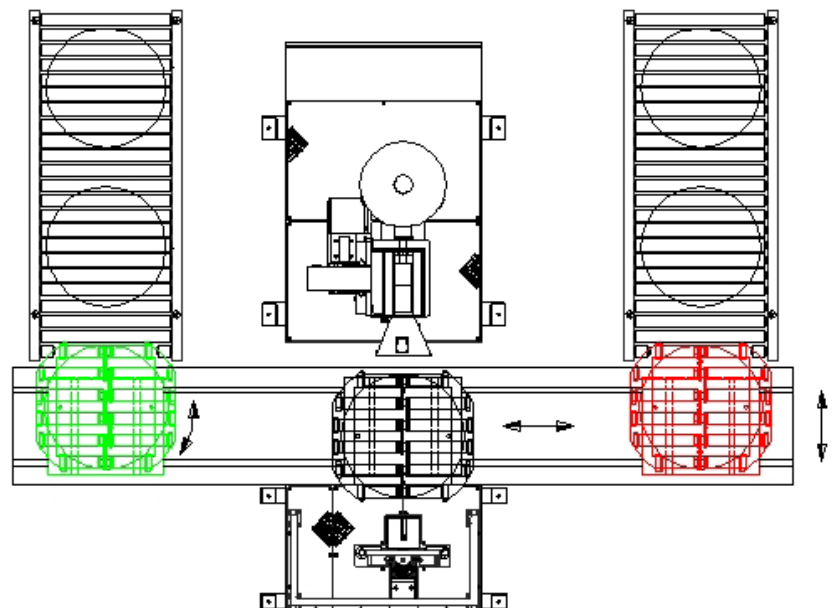

Plan view of the Model G3250-3850-320 Wide Range Segmented/Tomographic Gamma Scanner, showing U-shaped input and output conveyor for both 200L and 320L drums.

As part of an ongoing process of innovation, ANTECH® reserves the right to amend specifications without prior notice. Care was taken in compiling this document but ANTECH accepts no responsibility for its accuracy and reliability. It is acknowledged that all trademarks, logos and product data are the property of their respective owners.