

Liquid Ring Vacuum Pump LR1A200

Edwards offers a full range of liquid ring pumps. The LR1A200 provides a single-stage design and curved blade impellor with reinforcing rings for improved ruggedness, reducing noise and vibration.



All of our liquid ring pumps handle wet or dry gases, with high tolerance to liquid carry over. The LR1A Series has an enhanced bearing design enabling reduced internal clearances for improved efficiency. Pumps are available in cast iron and 316 stainless steel construction as standard with other materials and corrosion-resistant coatings available. All are tested to DIN 28431:1987 and are available as part of ATEX Category 1 and 2 T4 systems.

The LR1A200 is ideal for filtration, vacuum forming, general industrial and chemical and petrochemical applications.

Features and Benefits

- *Optional central partition enabling dual vacuum duty operation*
- *Variable area discharge port for optimum performance at all inlet pressures*
- *Packed gland, single and double mechanical seal options*
- *Split packing gland design to facilitate repacking*
- *Internal and external seal flushing options*
- *Internal recirculation option to reduce service liquid flow rate*
- *Optional inlet manifold and top-mounted separator to reduce footprint*

The LR1A200 is a bare-shaft machine and can be supplied as part of a standard package, incorporating electric motor, base-plate and seal liquid recovery system, suitable for once through, partial or total recirculation. Custom-engineered packages are also available, please contact your local office for more complex process system requirements.

Liquid Ring Vacuum Pump - LR1A200

Technical Data

Performance details

	50 Hz	60 Hz
Nominal capacity (saturated)	170 m ³ /hr/100 CFM	200 m ³ /hr/120 CFM
Suction pressure	33 mbar/25 Torr	33 mbar/25 Torr
Nominal speed	1450 rpm	1750 rpm
Nominal motor power	5.5 kW/7.5 HP	7.5 kW/10 HP

Speed Curves * Dry air at 20°C

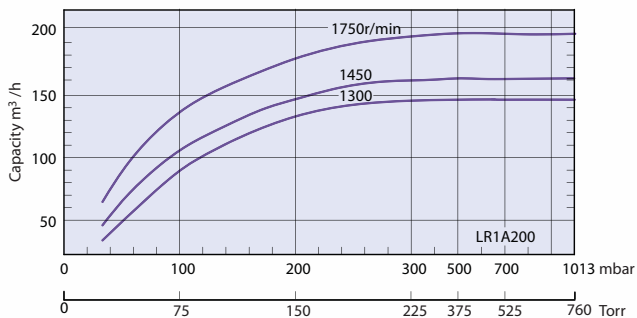

Power Curves

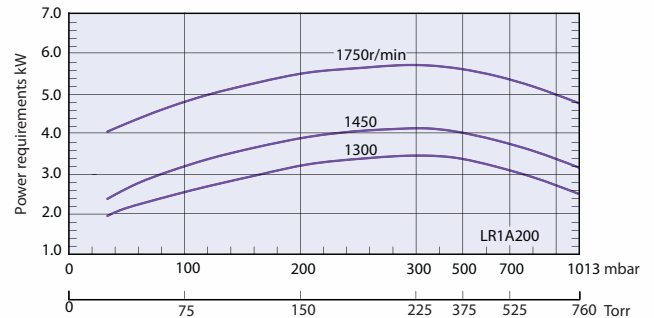

Dimensions

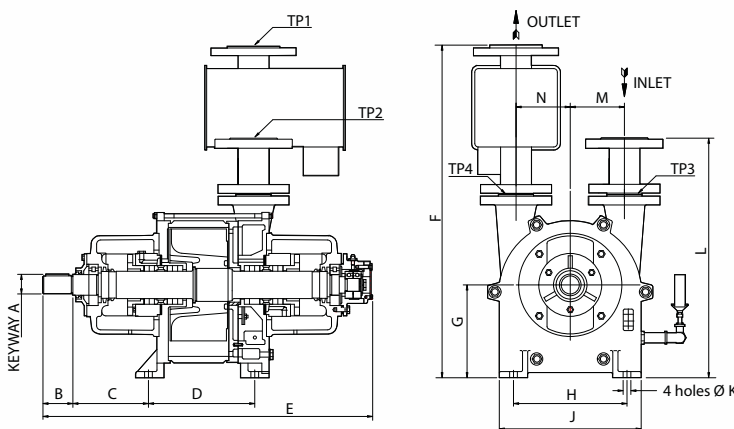

	MM	INCHES
A (Keyway)	38	1.50
B	58	2.28
C	146	5.75
D	206	8.11
E	639	25.16
F	645	25.39
G	180	7.09
H	220	8.66
J	275	10.83
K	Ø15	Ø 0.59
L	464	18.27
M	105	4.13
N	105	4.13
TP1	DN65, PN10	
TP2	DN65, PN10	
TP3	DN50, PN10	
TP4	DN50, PN10	

Flanges available to both DIN and ANSI standards

Global Contacts

EUROPE

UK Crawley +44 1293 528844
 UK Local Rate (UK only) 08459 212223
 Benelux Brussels +32 2 363 0030
 France Paris +33 1 47 98 24 01
 Germany Munich 0800 000 1456
 Italy Milan +39 02 48 4471

USA

Wilmington, MA +1 978 658 5410
 Toll free (USA only) +1 800 848 9800

ASIA PACIFIC

Taiwan R.O.C. Toufen Town +886 37 611422
 Singapore +65 6546 8408
 Australia +61 4 0199 1193

BRAZIL

Sao Paulo +55 11 3952 5000

CHINA

Shanghai +86 21 5866 9618

INDIA

Mumbai +91 22 2565 1177

ISRAEL

Qiryat-Gat +972 8 681 0633

KOREA

Bundang +82 31 716 7070
 Chunan I +82 41 621 7070
 Chunan II +82 41 622 7070

JAPAN

Yachiyo +81 47 458 8831



WWW.EDWARDSVACUUM.COM

info@edwardsvacuum.com

Rev 08/2007

Publication Number: LR1A200895, Issue B

© Edwards Limited 2007. All rights reserved.

Edwards and the Edwards logo are trade marks of Edwards Limited.